

## Optional Equipment

Work lights: 2 floodlights on boom cradle, 4 floodlights on upperstructure cab, 2 floodlights on left front upperstructure shrouding.

Windshield washer and wiper.

Vandalism protection kit: Lexan upperstructure cab windows, locking reservoir cap and sight gauge cover, metal window covers for undercarriage cab, locking engine hood, fuel cap and battery box.

Spark arrestor for upperstructure or undercarriage engine.

105 amp alternator, undercarriage.

Revolving beacon.

Cold start package for upperstructure engine: includes ether start kit and additional battery.

Cold start package for undercarriage engine: includes ether start kit (standard with 6BTA 5.9-200 engine), and additional battery.

Air conditioning for upperstructure or undercarriage cab.

Disc wheels, 6 x 4 undercarriage.

Inside hose trough with additional hosing and piping for pneumatic or hydraulic powered attachments.

360° continuous boom tilt.

Auxiliary oil cooler.

Telestick attachment.

Rear tandem axle: Meritor RT-44-145, 44,000 lb. (19,958kg).

*It is Gradall Policy to continually improve its products. Therefore designs, materials and specifications are subject to change without notice and without incurring any liability on units already sold. Units shown may have optional equipment.*

**GRADALL®**  
A JLG COMPANY

406 Mill Ave. SW, New Philadelphia, Ohio 44663  
Phone (330) 339-2211 Fax (330) 339-8468  
www.gradall.com

Certified ISO 9001

Form No. 10018 7/00  
Replaces Form No. 19811



Part No.	Description	Capacity (Cu. yd.)	Capacity (m <sup>3</sup> )
8065-6004	24" (610mm) Excavating bucket	3/8	.31
8065-6005	30" (762mm) Excavating bucket	1/2	.41
8065-6008	36" (914mm) Excavating bucket	5/8	.54
8065-6010	42" (1.07m) Excavating bucket	3/4	.64
8065-6001	48" (1.22m) Excavating bucket	1	.76

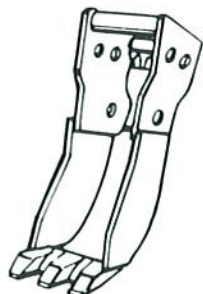

Part No.	Description	Capacity (Cu. yd.)	Capacity (m <sup>3</sup> )
8065-6011	15" (381mm) Trenching bucket	1/5	.15
8065-6012	21" (533mm) Trenching bucket	1/4	.19



8065-6030 40" (1.02m) Pavement removal bucket

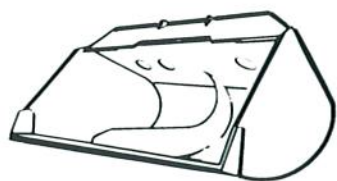

Part No.	Description	Capacity (Cu. yd.)	Capacity (m <sup>3</sup> )
8065-6007	60" (1.52m) Ditching bucket	7/8	.73
8065-6006	66" (1.68m) Ditching bucket	1	.76
8065-6002	72" (1.83m) Ditching bucket	1 1/8	.87



8065-6013 72" (1.83m) Dredging bucket



8065-6009 Single-tooth ripper



8065-6015 Industrial hook

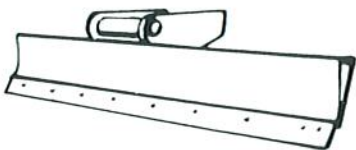

8065-6024 8' (2.4m) Grading blade

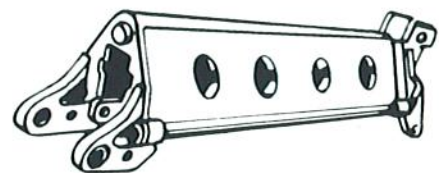

8065-5013 4' (1.2m) Boom extension  
8065-5014 6' (1.8m) Boom extension  
8065-5015 8' (2.4m) Boom extension  
8065-5016 12' (3.7m) Tubular Boom extension  
8065-5005 Telestick attachment

### ATTACHMENTS

Buckets fabricated of steel plate, with high strength, low alloy cutting edges and wear strips. Standard attachments available for wide range of applications. Capacities shown are in heaped cu. yd.

### TWO POSITION BUCKET

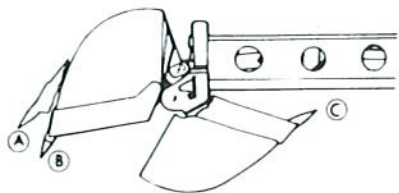

A- Bucket open, lower pin position, for vertical walls or deep excavating. Bucket pivot 165°.  
B- Bucket open, upper pin position, for most applications. Bucket pivot 135°.  
C- Bucket closed, either pin position.

# GRADALL

## XL 4100

### HYDRAULIC EXCAVATOR



## SPECIFICATIONS

### Upperstructure Engine

Cummins 6BT5.9 diesel, turbocharged, liquid cooled, 4 cycle, 6 cylinder, 359 cid (5.9L), 4.02" bore x 4.72" stroke (102mm x 120mm), 17.4:1 compression ratio.

150 hp (112kW) max gross at 2000 rpm, 148 hp (110kW) gross at engine gov. speed of 2200 rpm, 138 hp (103kW) net at 2000 rpm, 440 ft.-lb. (597 Nm) gross torque at 1600 rpm.

Altitude capability 10,000' (3050m). Derate 4% per 1000' (305m) above 10,000' (3050m).

Maximum slope: 45°.

12 volt starter, 105 amp alternator, two SAE #C31-S 810 CCA batteries, two-stage dry type air cleaner with centrifugal precleaner, ejector valve and service indicator, spin-on oil filter, spin-on fuel filter/water separator.

Fuel tank capacity: 65 gallons (246L).

### Hydraulic System

#### PUMPS

- Main** Two load sensing axial piston pumps; 0-60 GPM (0-227 L/min) each.
- Swing** Axial piston pump; 0-16 GPM (0-61 L/min).
- Auxiliary** Tandem gear pump for pilot control and cooling circuits; 20.6 GPM (78 L/min).

#### SYSTEM MONITOR

Electronic monitor in cab indicates low hydraulic fluid level, high hydraulic fluid temperature, and condition of return and suction filters.

#### SYSTEM SPECIFICATIONS

- Four double acting cylinders**
  - 2 boom hoist: 5.0" ID, 3.0' rod (127mm x 76mm), 26.25" (667mm) stroke.
  - 1 tool: 5" ID, 3.0" rod (127mm x 76mm), 18.875" (479mm) stroke.
  - 1 telescope: 4" ID, 2.75" rod (102mm x 70mm), 12.6' (3.81m) stroke.

#### Four hydraulic motors

Swing, 53 hp (39kW); tilt, 26 hp (19kW); Remote Drive 115 hp (86kW), 127 hp. Opt. Engine (95kW).

#### Operating pressures

Hoist	. . . . .	3900 psi (26,871kPa)
Tilt	. . . . .	2800 psi (19,292kPa)
Swing	. . . . .	5700 psi (39,273kPa)
Tool	. . . . .	4300 psi (29,627kPa)
Telescope	. . . . .	3250 psi (22,393kPa)
Remote Propel	. . . . .	3800 psi (26,183kPa)
Opt. Engine	. . . . .	4200 psi (28,939kPa)
Pilot system	. . . . .	480 psi (3,307kPa)

#### Oil capacity

Reservoir 75 gallons (284L), system 95 gallons (360 L). Pressurized reservoir with visual oil level gauges.

#### Filtration system

Combination of 8 micron and 10 micron in-line suction and return filters, plus 10 micron return filter, magnet and 100 mesh strainer in reservoir.

Fin and tube-type oil cooler, with thermal by-pass and relief valves.

Pressure compensated load-sensing valves with circuit reliefs in all valves.

### Upperstructure Cab

All-weather cab with tinted safety glass windows, skylight, acoustical lining, four-way adjustable operator's seat, filtered fresh air heater and defroster. Front window slides to overhead storage. Mirrors on both sides of machine.

### Controls

Two hydraulic joysticks (hoist & bucket, telescope & swing), one rocker switch (tilt) control upperstructure. Hydraulic joysticks mounted on arm rests, independently adjustable for individual operator comfort and convenience.

Two foot pedals for hydraulic remote control of undercarriage steering, travel and digging brakes.

Joysticks and pedals are self-centering; when controls are released, power for movement disengages and swing and travel brakes set automatically.

#### Engine controls

Key operated ignition/starter switch, throttle, hour meter and air cleaner condition indicator. Electronic monitor indicates fuel level, low battery charge, coolant level and lube oil pressure, high coolant temperature, and engine rpm.

### Swing

Independent closed loop swing circuit with axial piston pump and motor. Planetary transmission.

Swing speed: 8.0 rpm.

#### Swing brake

Automatic swing parking brake, spring-set hydraulic release. Dynamic braking provided by hydraulic system.

### Undercarriage

6x4 or 6x6

Wheelbase: 171" (4.3m)

Frame width: 42" (1070mm)

Gross vehicle axle weight rating:

6 x 4 - 59,200 lb. (26,853 kg)

6 x 6 - 62,000 lb. (28,132 kg)

### Engine

Cummins 6BTA5.9 diesel, turbocharged and aftercooled, 4 cycle, 6 cylinder, 359 cid (5.9L), 4.02" bore x 4.72" stroke (102mm x 120mm) 200 hp (149kW) gross at 2500 rpm, 185 hp (138kW) net at 2500 rpm. Throttle stop limited to 2500 rpm hi-idle no load. (200 hp at 2200 rpm loaded.) 600 ft.-lb. (814Nm) gross torque at 1500 rpm. Altitude capability 9850' (3000m). Derate 4% per 1000' (300m) above 9850' (3000m).

#### Option Engine

Cummins 6CTA8.3 diesel, turbocharged and aftercooled, 245 hp (183kW) max gross at 2000 rpm, 230 hp (172kW) gross at engine gov. speed of 2200 rpm, 720 ft lb (976Nm) torque at 1500 rpm.

#### Electrical System

12 volt, 62 amp alternator with integral voltage regulator. Batteries: 2 SAE #C31S 810 CCA

#### Cooling System

Fin and tube-type radiator. 6-blade 24" (610 mm) fan with shroud. 8-blade fan with optional engine.

#### Fuel System

50 Gallon (189L) fuel tank, spin-on fuel filter/water separator.

#### Air Filter

Dry type with service indicator.

#### Oil Filter

Full flow spin-on element.

#### Governor

Mechanical.

**Transmission**  
 6 x 4 with Cummins 6BTA5.9 or 6CTA8.3 engine: Fuller RTO-11908LL Roadranger, 10 speeds forward, 3 speeds reverse, air controlled countershaft brake.  
 6 x 6 with Cummins 6BTA5.9 or 6CTA8.3 engine: Fuller RTO-11908LL Roadranger and Fabco 170 Series transfer case with air controlled front drive declutch.

**Travel Speed**, 6x4 or 6x6 mph (km/hr) (std. engine)

LoLo	Lo	1	2	3	4	5	6	7	8
3(4)	4(7)	6(10)	8(13)	11(18)	15(24)	21(34)	28(45)	38(61)	52(83)
									Option Engine 56(90)

R1	R2	R3
3(4)	4(6)	13(21)

• Clutch  
 14" (356mm) single plate, pull type.

• Drive Lines  
 Spicer 1760 series with needle bearing, universal joints.

• Axles  
 Front: 6 x 4-Meritor FF962, 13,200 lb. (5,988kg) rating.  
 6 x 6 Meritor RF-16-145, 16,000 lb. (7,258kg) rating. 7.17 ratio (Opt. engine 6.43 ratio).  
 Rear: Meritor RT-46-160, 46,000 lb. (20,886kg) rating, single reduction, straight line drive, 7.17:1 ratio. (Opt. engine 6.43 ratio.) Cab controlled differential lock in forward-rear axle, cab controlled interaxle differential lock.

**Frame**  
 Wide-flange beam, 12" (305mm), 35 lb/ft (52kg/m).

**Suspension**  
 Front: 14 leaf spring, 41.38" x 3" (1.05m x 76mm), automatic lockout cylinders.  
 Rear: Hendrickson equalizer beam, 8" (196mm) oscillation.

**Brakes**  
 Meritor P<sup>+</sup> Series Cam-Master spring-set cam brakes on rear. 6 x 4-cam brakes on front; 6 x 6-cam brakes on front.  
 Auto-slack adjusters.  
 Front drums: 6 x 4-16.5" x 5" (419mm x 127mm),  
 6 x 6-16.5" x 6" (419mm x 152mm).  
 Rear drums: 16.5" x 7" (419mm x 178mm).  
 Spring brake system incorporates emergency and parking brakes on both rear axles.

## GRADALL XL 4100 6x4 & 6x6 Lift Capacity Over Side or Rear - LB. (KG.)

**CAUTION:** All rated loads are based on the machine being stationary and level on a firm supporting surface. For safe working loads, the user is expected to make due allowance for his particular job conditions, such as soft or uneven ground, out of level conditions, side loads, hazardous conditions, experience of personnel, etc. The operator and other personnel should fully acquaint themselves with the Operator's Manual furnished by the manufacturer before operating this machine, and rules for safe operation of equipment should be adhered to at all times.

The above loads are in compliance with SAE Standard J-1097 Nov88. They do not exceed 87% of hydraulic lifting capacity or 75% of tipping capacity.

All loads with an asterisk (\*) indicate the load is limited by tipping rather than hydraulic capacity. The rated lift capacity is based on the machine being equipped with 5600 lbs. (2540kg) counter-weight, standard tires, and 8065-6008 36" (914mm) excavating bucket weighing 780 lbs. (354kg). For other buckets adjust the listed capacities as follows:

8065-6006 66" (1.68m) ditching - subtract 245 lbs. (111kg)  
 8065-6010 42" (1.07m) excavating - subtract 130 lbs. (59kg)  
 8065-6001 48" (1.22m) excavating - subtract 260 lbs. (118kg)  
 8065-6004 24" (610mm) excavating - add 260 lbs. (118 kg)

Desiccant type air dryer with automatic purge valve and thermostatically controlled heater. 13.2 cfm (6.2L/sec) air compressor.

**Wheels**  
 6 x 4-cast spoke with demountable rim.  
 6 x 6-disc, 10 stud. 11.25" (286mm) bolt circle.

**Steering**  
 Ross, integral hydraulic power steering.

**Tires**  
 Single front: 6 x 4-15.00 x 22.5-14PR, highway tread  
 6 x 6-15.00 x 22.5-16PR, traction tread  
 Dual rear: 6 x 4-10.00 x 20-14PR, traction tread  
 6 x 6-10.00 x 20-14PR, traction tread  
 Optional: 10:00 x 20-14PR, highway tread, 6 x 4 front & rear  
 10:00 x 20-14PR, traction tread, 6 x 6 front

**Undercarriage Cab**  
 One man, left hand mounted, isolated from frame on rubber mounts. Bostrom T-Bar seat, adjustable front and back. Tinted safety glass windows, sliding windows left and right. Cowl ventilator, acoustical lining, sun visor, fire extinguisher, seat belt, heater and defroster.

**Standard Equipment (Undercarriage)**  
 Sealed beam headlights, tail lights, back-up lights, stop lights, neutral start switch, identification light clusters front & rear, direction signals, 4-way hazard lights, clearance lights, instrument lights, dome light. Oil pressure, water temperature, dual air tank pressure and fuel gauges; voltmeter, tachometer, hour meter, speedometer and odometer. Windshield washer and wiper. Wide angle rear view mirror system with plane and convex mirrors left and right. Wheel and axle wrenches. Left rear fender step.

## Hydraulic Remote Control

Undercarriage powered by upperstructure engine through hydraulic motor and PTO on transmission. Travel and steering pedals in upperstructure cab. Digging brakes and front axle lockout cylinders set automatically with travel pedal in neutral. Emergency/parking brakes controlled by toggle. Undercarriage engine off when hydraulic remote control is in use.

Electrically operated alarms mounted on undercarriage signal remote control movement in either direction, reverse movement when driven from undercarriage cab. Alarms meet SAE-J-994b type B classification.

LOAD POINT HEIGHT	LOAD RADIUS	LOAD RADIUS										
		12' (3.6m)		15' (4.6m)		20' (6.1m)		25' (7.6m)				
		Over End	Over Side	Over End	Over Side	Over End	Over Side	Over End	Over Side			
Above Ground Level	15' (4.6m)			7860 (3565)	7860 (3565)	5290 (2400)	5290 (2400)	3655 (1660)	3655 (1660)	25' 6" (7.8m)	3520 (1600)	3520 (1600)
	10' (3m)			9905 (4450)	9905 (4450)	6255 (2840)	6255 (2840)	4215 (1910)	*4210 (1910)	26' 9" (8.2m)	3690 (1670)	*3680 (1670)
	Boom Level 8' 6" (2.4m)			10225 (4640)	*10025 (4550)	6470 (2935)	*6240 (2830)	4345 (1970)	*4175 (1895)	26' 11" (8.2m)	3755 (1705)	*3610 (1640)
	5' (1.5m)			10610 (4810)	*9725 (4410)	6755 (3065)	*6290 (2865)	4540 (2060)	*4090 (1855)	27' 0" (8.2m)	3910 (1775)	*3520 (1600)
At Ground Level				9880 (4480)	*9250 (4195)	6615 (3000)	*5850 (2655)	4560 (2066)	*3950 (1790)	26' 2" (8.0m)	4175 (1895)	*3610 (1635)
	Below Ground Level	5' (1.5m)	10680 (4845)	10680 (4845)	8265 (3750)	8265 (3750)	5980 (2715)	5630 (2550)		24' 4" (7.4m)	4400 (2040)	*4010 (1820)
		10' (3m)	7830 (3550)	7830 (3550)	6645 (3015)	6645 (3015)	5150 (2335)	5150 (2335)			20' 11" (6.4m)	4900 (2220)
15' (4.6m)		5960 (2705)	5960 (2705)									

The load point is located on the bucket pivot point, including loads listed for maximum radius. Do not attempt to lift or hold any load greater than these rated values at specified load radii and heights. The weight of slings and any auxiliary lifting devices must be deducted from the rated load to determine the net load that may be lifted.

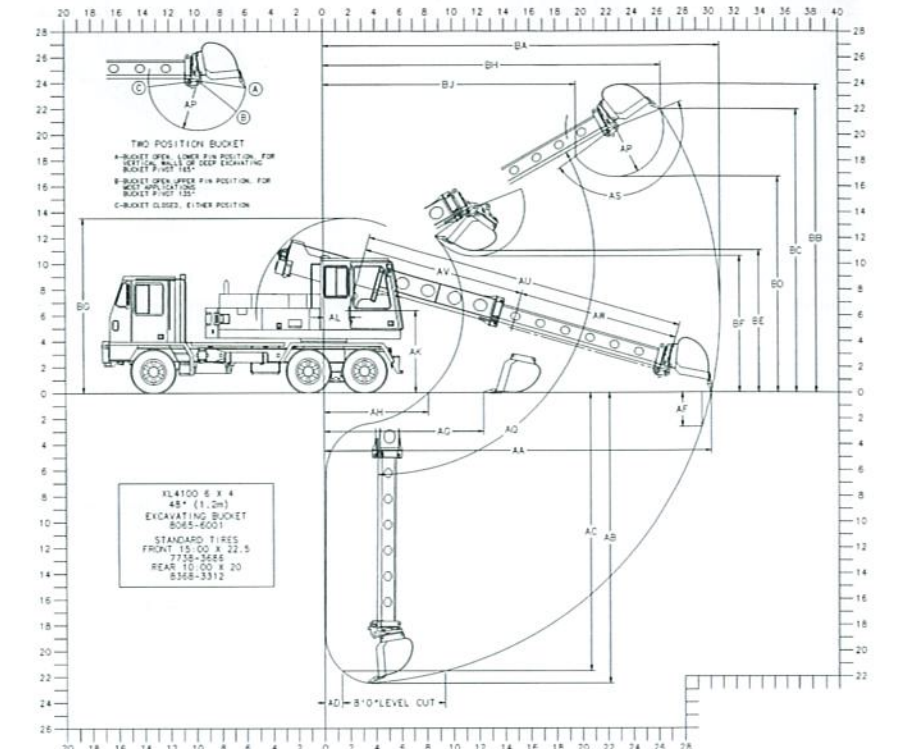
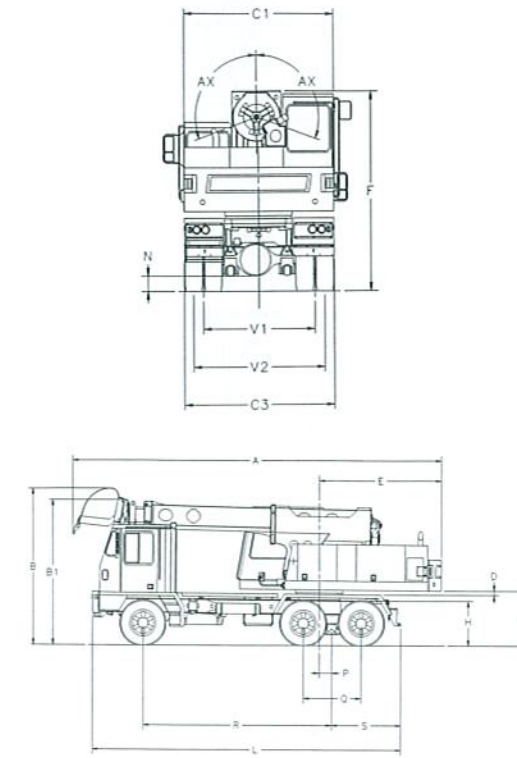

## Shown with 8065-6001 48" (1.22m) excavating bucket

	6 x 4	6 x 6		6 x 4	6 x 6	
A	27' 11" (8.5m)	27' 11" (8.5m)	Overall length (boom in rack) with bucket	AV 12' 6" (3.8m)	12' 6" (3.8m)	Minimum telescoping boom length (boom pivot to bucket pivot)
B	11' 10" (3.6m)	12' 3" (3.7m)	Overall height (boom in rack) with bucket			Telescoping boom travel
B1	10' 11" (3.3m)	11' 4" (3.4m)	Overall height (boom in rack) without bucket	AW 12' 6" (3.8m)	12' 6" (3.8m)	Boom tilt angle (both sides of center)
C1	8' 0" (2.4m)	8' 0" (2.4m)	Width of upperstructure	BA 30' 10" (9.4m)	30' 10" (9.4m)	Maximum radius of working equipment (165° pivot)
C3	8' 0" (2.4m)	8' 0" (2.4m)	Width of undercarriage			Maximum height of working equipment
D	4" (100mm)	4" (100mm)	Minimum clearance, upperstructure to undercarriage	BB 23' 10" (7.3m)	24' 0" (7.3m)	Maximum bucket tooth height
E	9' 3" (2.8m)	9' 3" (2.8m)	Swing clearance, rear of upperstructure	BC 21' 11" (6.7m)	22' 1" (6.7m)	Minimum clearance of bucket teeth, with bucket pivot at maximum height
F	10' 7" (3.2m)	10' 10" (3.3m)	Top of cradle to ground line	BD 16' 8" (5.0m)	16' 10" (5.1m)	Minimum clearance of fully curled bucket at maximum boom height (165° pivot)
G	50" (1.3m)	53" (1.3m)	Clearance, upperstructure to groundline	BE 11' 0" (3.3m)	11' 3" (3.4m)	Minimum clearance of bucket teeth at maximum boom height
H	41" (1m)	44" (1.1m)	Top of wheel mounted under carriage frame to groundline	BF 10' 6" (3.2m)	10' 9" (3.3m)	Minimum clearance of bucket teeth at maximum boom height
L	23' 4" (7.1m)	23' 4" (7.1m)	Overall length of undercarriage	BG 13' 6" (4.1m)	13' 10" (4.2m)	Maximum height of working equipment with bucket below groundline
N	10" (250mm)	10" (250mm)	Ground clearance (per SAE J1234)	BH 26' 3" (8.0m)	26' 4" (8.0m)	Radius of bucket teeth at maximum height (165° pivot)
P	11" (280mm)	11" (280mm)	Center of rear tandem to axis of rotation	BJ 19' 7" (5.9m)	19' 8" (6.0m)	Minimum radius of bucket teeth at maximum bucket pivot height (165° pivot)
Q	52" (1.3m)	52" (1.3m)	Distance between centers of tandem axles			
R	14' 3" (4.3m)	14' 3" (4.3m)	Wheelbase			
S	5' 3" (1.6m)	5' 3" (1.6m)	Center of tandem axles to rear of frame (step)			
V1	5' 11" (1.8m)	5' 11" (1.8m)	Tread, rear axles			
V2	6' 8" (2.0m)	6' 8" (2.0m)	Tread, front axle			
AA	30' 1" (9.2m)	30' (9.1m)	Maximum radius at groundline (165° pivot)			
AB	22' 6" (6.8m)	22' 2" (6.7m)	Maximum digging depth (165° pivot)			
AC	21' 6" (6.6m)	21' 3" (6.5m)	Maximum depth for 8' level cut			
AD	16" (400mm)	14" (355mm)	Minimum radius of 8' level cut at depth "AC"			
AF	32" (800mm)	30" (762mm)	Maximum depth of vertical wall which can be excavated			
AG	12' 4" (3.7m)	12' 0" (3.6m)	Minimum level cut radius with bucket flat on groundline			
AH	8' 2" (2.4m)	7' 10" (2.4m)	Minimum radius at groundline			
AK	6' 4" (1.9m)	6' 8" (2.0m)	Boom pivot to groundline			
AL	22.5" (570mm)	22.5" (570mm)	Boom pivot to axis of rotation			
AP	46" (1.2m)	46" (1.2m)	Bucket tooth radius			
AQ	30° Up & 90° Down	30° Up & 90° Down	Boom pivot angle			
AS	135° & 165°	135° & 165°	Bucket pivot angle			
AU	25' 0" (7.6m)	25' 0" (7.6m)	Maximum telescoping boom length (boom pivot to bucket pivot)			

Rated bucket tangential force with 36" (914mm) bucket: 18,900 lb. (84kN)  
 Rated telescoping boom crowd force: 21,650 lb. (96.4kN)

### TRAVEL DIMENSIONS

Boom in rack, without bucket-  
 Overall length:  
 26' 5" (8.1 m)

Overall height:  
 6 x 4-10' 11" (3.3m)  
 6 x 6-11' 4" (3.5m)

### WEIGHT

Approximate working weight, including 36" (914mm) bucket, fuel tanks half full -  
 6 x 4: 45,660 lb. (20,711kg)  
 6 x 6: 47,410 lb. (21,505kg)

Specifications subject to change without notice.