

GRADALL®

XL 3100 III



XL 3100 III

SPECIFICATIONS

Undercarriage

4 x 2 or 4 x 4
Wheelbase: 156" (3.96m)
Width 102" (2.6m)

Frame:
48" (1.2m) wide, welded plate design
65 ksi material

Gross vehicle axle weight rating:
4 x 2 41,000 lb (18,597 kg)
4 x 4 44,000 lb (19,958 kg)

Front axles:
4 x 2: Meritor Model MFS-16-122A, 16,000 lb (7,257 kg) rating
4 x 4: Meritor Model MX19-145, 19,000 lb (8,618 kg) rating, 7.17 ratio

Rear axle:
Meritor Model RS25-160, 25,000 lb (11,340 kg) rating, 7.17 ratio, single reduction with driver controlled differential lock

Suspension:
Front: 8 leaf spring with automatic lock-out cylinders
Rear: Solid mount

Brakes:
4 x 2 Front: Meritor "Q" Series Cam-Master
Size: 16.5" x 5" (419 mm x 152 mm)
Automatic Slack Adjusters

4 x 4 Front: Meritor "Q" Series Cam-Master
Size: 16.5" x 6" (419 mm x 127 mm)
Automatic Slack Adjusters

4 x 4 Rear and 4 x 2 Rear: Meritor "P" Series
Cam-Master Size: 16.5" x 7" (419 mm x 178 mm)
Automatic Slack Adjusters

Spring brake system incorporates emergency and parking brakes on the rear axle.

Wheels:
Hub piloted disc 10-stud, 11.25" (286 mm) bolt circle.

Tires:
4 x 4 front: 425/65R22.5 20-ply on/off highway traction tread
4 x 2 front: 385/65R22.5 18-ply on/off highway tread
4 x 2 and 4 x 4 rear: 11R24.5 16-ply on/off highway traction tread

Steering:

Ross, integral hydraulic power steering. Gear type power steering pump. 4-quart power steering reservoir with filter.

Standard chassis equipment:

Halogen headlights, tail lights, back-up lights and alarm, stoplights, identification lights front and rear, directional lights, 4-way hazard lights, work lights, and instrument panel lights. Windshield wiper/washer, West Coast style mirror system with plane and convex mirrors, front and rear tow hooks, desiccant type air dryer with automatic purge valve and thermostatically controlled heater.

Hydraulic System

PUMPS

One load-sensing axial piston pump; 8-55 GPM (30-208 L/min) total.
1 Gear Pump 11GPM (42L/min)

SYSTEM SPECIFICATIONS

Four double acting cylinders:

- 2 hoist cylinders: 3.5" x 2.56" Rod x 31" stroke 89mm x 65mm x 787mm
- 1 tool cylinder: 4.25" Borex 3.0" Rod x 25.9 stroke (108mm x 76 x 658)
- 1 telescope: 3.5" ID, 2.559" Rod (89mm x 65mm), 11'(3.34m) stroke

Four hydraulic motors:

Swing, 51 Hp (38kW); tilt, 21 Hp (16kW); two remote drive, 88 Hp (65kW) total.

Operating pressures:

Hoist	4,800 psi (331 BAR)
Tilt	2,500 psi (172 BAR)
Swing	3,000 psi (206 BAR)
Tool	4,800 psi (331 BAR)
Telescope	4,800 psi (331 BAR)
Remote Propel	3,750 psi (258 BAR)
Pilot system550 psi (38 BAR)

Oil capacity:

Reservoir 35 gallons (133 L), system 50 gallons (189 L). Pressurized reservoir with visual oil level gauges.

Filtration system:

10 micron return filter.
10 micron pilot filter.
Fin and tube-type oil cooler with thermostatically controlled cooling fan.

Pressure-compensated, load-sensing valves with circuit reliefs in all circuits.

Chassis Cab

One-person cab, left-hand mount, isolated from frame on rubber mounts. Acoustical lining. Sun visor. Gauges for oil pressure, coolant temperature, air tank pressures, fuel level, voltmeter, speedometer with odometer, tachometer, hour meter. Engine monitor lights. Engine shutdown controlled by engine electronics. Indicator lights and controls for front axle engagement (4 x 4 only) and rear axle differential lock. Park brake control. Tinted safety glass. Sliding side windows. Fresh air heater and defroster. Dome light. Air suspension seat with seat belt. Vent in door.

Upperstructure Cab

All-weather cab isolated from frame on rubber mounts. Tinted safety glass windows, skylight, acoustical lining, four-way adjustable operator's seat, dome light, filtered air heater and defroster. AM/FM Radio, Air-Conditioning work light package.

The heat source is provided by a fast response, closed circuit hydraulic heater with 20,000 BTU/Hr. capacity.

Front window slides to overhead storage. Rearview mirrors on right and left sides of the machine. Windshield wiper and washer.

Hydraulic Remote Control

Undercarriage powered by upperstructure hydraulics through hydraulic motors and PTOs on transmission. Travel and steering pedals in upperstructure cab. Digging brakes and front axle lockout cylinders set automatically with travel pedal in neutral. Parking brakes controlled by toggle.

Electrically operated alarm mounted on undercarriage signal remote control movement in either direction, reverse movement when driven from undercarriage cab.

Engine

Detroit Diesel OM906 diesel with EGR. 4 cycle, inline 6 cylinder, liquid cooled. Turbo/Charge air aftercooled. Off-road Certified. Electronic controlled. Vertical canister style lube filter attached to engine. Vertical canister style fuel filters, (main and pre-filter) attached to engine. Remote mount primary fuel/water separator. Gross Rating: 201HP @ 2200 RPM. 553 FT LB Torque @ 1200 RPM. Net Rating: 184 HP @ 2200 RPM.

Air Filter: 2-stage dry type with safety element, ejector valve and service indicator.

Electrical System: 12 volt, 100 amp alternator with integral voltage regulator. 2 SAE #C31-S 1000 CCA batteries.

Variable Viscous Fan Clutch System: Fin and tube radiator with fan shroud. 9 blade, 28" diameter fan. Engine charge air cooler mounted in front of radiator. Transmission oil cooler mounted in front of radiator below charge air cooler.

Fuel Tank Capacity: 100 gal (378 L)

Transmission: Eaton Roadranger RTX-14609B, 9-speed FWD, 2-speed reverse. Internal oil pump with external spin-on filter. Transmission oil cooler. Neutral start switch. Input shaft clutch brake. 8-bolt air shifted PTO for hydraulic pump drive. Dual rear countershaft, air shifted PTO's for remote propel motors.

Gear Speeds: (with 11R24.5 tires)

Gear	Lo	1	2	3	4	5	6	7	8*
MPH	3.1	5.2	7.4	10.2	14.0	20.0	28.3	39.0	53.4
Km/hr	(4.9)	(8.4)	(11.9)	(16.4)	(22.5)	(32.2)	(45.3)	(62.7)	(85.9)

Gear	Rev Lo	Rev Hi
MPH	3.4	13.1
Km/hr	(5.5)	(21.1)

*Limit speed to 50mph with 445/65R22.5 tires.

Clutch: Hydraulic actuated. Spicer Model 107, pull type. 14" dia, 2-plate, organic disc.

Drivelines: Spicer 1760 Series with "Half Round" yokes.

Transfer Case: (4 x 4 only) Meritor Model T-211HD, 1/1 ratio, 3 shaft single speed. With air operated front axle disconnect.

GRADALL Model XL 3100 III Lift Capacity Over Side or Rear - LB. (KG.)

LOAD POINT HEIGHT		LOAD RADIUS										
		10' (3.0m)		15' (4.6m)		20' (6.1m)		25' (7.6m)		Maximum Radius	Over End	Over Side
		Over End	Over Side	Over End	Over Side	Over End	Over Side	Over End	Over Side			
Above Ground Level	19'6" (6.1m)									20'2" (6.1m)	3625 (1645)	3625 (1645)
	15' (4.6m)			6475 (2935)	6475 (2935)	4320 (1960)	4320 (1960)			22'8" (6.9m)	3545 (1610)	3545 (1610)
	10' (3.0m)			7655 (3470)	7655 (3470)	4890 (2220)	4890 (2220)			24'0" (7.3m)	3560 (1615)	3560 (1615)
	BOOM LEVEL 8' 8" (2.7m)			7840 (3555)	7840 (3555)	4975 (2255)	4975 (2255)			24'2" (7.4m)	3575 (1620)	3575 (1620)
	5' (1.5m)			7870 (3570)	7870 (3570)	5050 (2290)	5045 (2290)			24'2" (7.4m)	3625 (1645)	3625 (1645)
At Ground Level				6840 (3105)	6840 (3105)	4710 (2135)	4710 (2135)			23'3" (7.1m)	3720 (1685)	3720 (1685)
Below Ground Level	5' (1.5m)	5920 (2685)	5920 (2685)	5920 (2685)	5920 (2685)	4030 (1830)	4030 (1830)			21'0" (6.4m)	3785 (1715)	3785 (1715)
	10' (3.0m)	3590 (1630)	3590 (1630)	3860 (1750)	3860 (1750)					16'11" (5.1m)	3665 (1660)	3665 (1660)
	14'4" (4.4m)									9'9" (3m)	2155 (975)	2155 (975)

NOTE: The above loads are in compliance with SAE standard J1097 DEC2005. They do not exceed 87% of hydraulic lifting capacity or 75% of the tipping capacity.

The rated lift capacity is based on the machine being equipped with 6,000 lb (2720 kg) counterweight, standard boom, standard tires, no auxiliary hydraulics, and no bucket. Adjust the listed rated capacities by subtracting the value listed for bucket/attachment used:

8065-6007 60" (1.5m)	Ditching-	807lbs.	(366kg)
8065-6006 66" (1.7m)	Ditching-	892lbs.	(405kg)
8065-6002 72" (1.8m)	Ditching-	944lbs.	(428kg)
8045-6020 24" (610mm)	Excavating	603lbs.	(274kg)
8045-6021 30" (762mm)	Excavating	660lbs.	(300kg)
8045-6022 36" (914mm)	Excavating	741lbs.	(336kg)
8045-6023 42" (1.1m)	Excavating	841lbs.	(382kg)
8045-6024 48" (1.2m)	Excavating	957lbs.	(434kg)
8065-6013 72" (1.8m)	Dredging	1114lbs.	(505kg)
8065-6102 40" (1.0m)	Pavement	1262lbs.	(573kg)
8065-6024 8' (2.4m)	Blade	630lbs.	(285kg)
8065-6009 Single Tooth Ripper	Ripper	557lbs.	(253kg)

Upperstructure Controls

Two electronic joysticks (hoist & bucket, telescope & swing), one rocker switch (tilt) control upperstructure. Joysticks are mounted on arm pods that are adjustable for individual operator comfort and convenience. Quick change joystick pattern switch located on instrument panel.

Two foot pedals for remote control of undercarriage steering, travel and digging brakes. Rocker switch on control panel selects low speed or high speed remote travel.

Joysticks and pedals are self-centering; when controls are released, power for movement disengages and swing and travel brakes set automatically.

Engine Controls

Key ignition switch with neutral start and indicator lights for low air, engine status, park brake, travel status, hydraulic fluid temperature and level.

Automatic engine shut down occurs with low oil pressure or high coolant temperature.

Swing

Priority swing circuit with axial piston motor. Planetary transmission. Swing speed: 8 rpm.

Swing brake: Automatic spring-set/hydraulic release wet disc parking brake. Dynamic braking is provided by the hydraulic system.

Loads shown in shaded areas indicate the load is limited by tipping rather than hydraulic lift capacity

The load point is located on the bucket pivot point, including load listed for maximum radius.

Do not attempt to lift or hold any load greater than these rated values at specified load radii and heights. The weight of slings and any auxiliary devices must be deducted from the rated load to determine the net load that may be lifted.

ATTENTION: All rated loads are based on the machine being stationary and level on a firm supporting surface. For safe working loads, the user must make allowance for his particular job conditions such as soft or uneven ground, out of level conditions, side loads, hazardous conditions, experience of personnel, etc. The operator and other personnel must fully acquaint themselves with the Operator's Manual furnished by the manufacturer before operating this machine. Rules for safe operation of equipment must be adhered to at all times.

NOTE: Bucket adjustment values are 87% of the actual bucket weights.

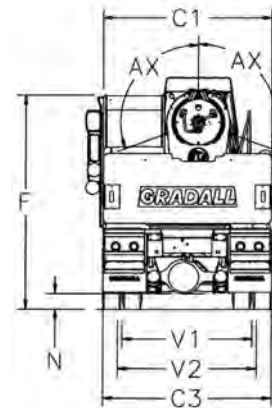
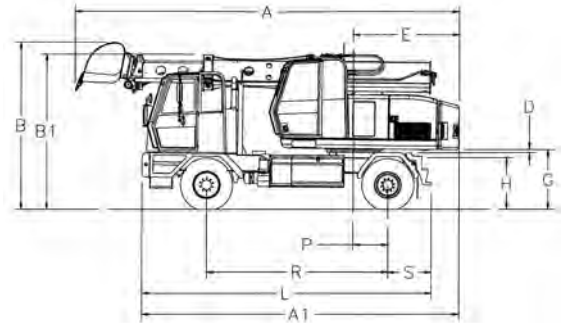
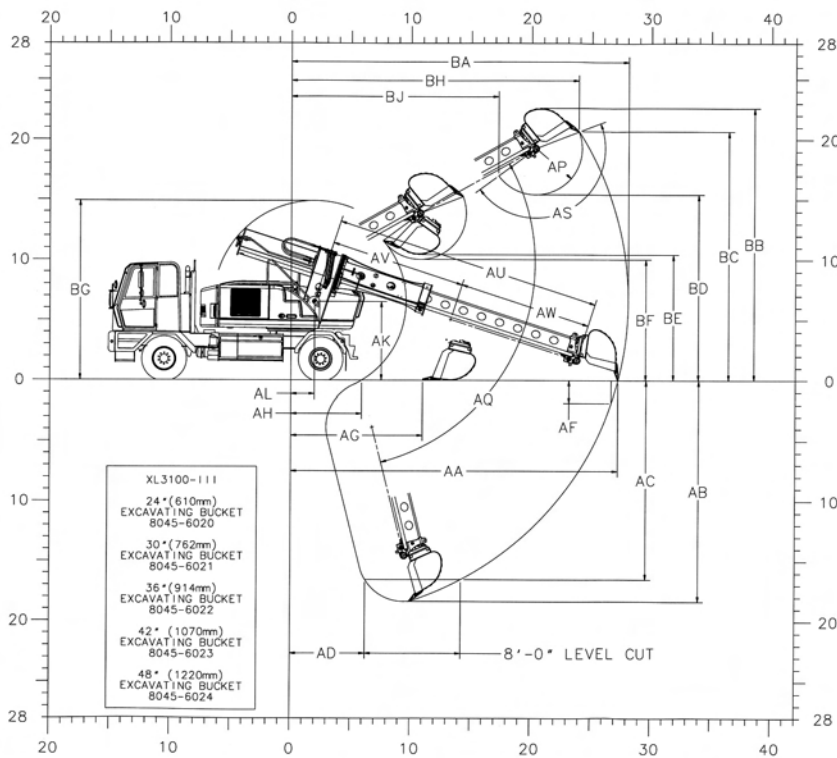

Shown with 8035-6006 30" (762mm) excavating bucket

4 x 4	4 x 2	
A 27'3" (8.3m)	27'3" (8.3m)	Overall length (boom in rack) with bucket
A1 22'7" (6.9m)	22'8" (6.9m)	Overall length (boom in rack) without bucket
B 12'11" (3.9m)	12'8" (3.9m)	Overall height (boom in rack) with bucket
B1 11'6" (3.5m)	11'3" (3.4m)	Overall height (boom in rack) without bucket
C1 8'6" (2.6m)	8'6" (2.6m)	Width of upper structure
C3 8'6" (2.6m)	8'6" (2.6m)	Width of undercarriage
D 2" (50mm)	2" (50mm)	Minimum clearance, upperstructure to undercarriage
E 7'6" (2.3m)	7'6" (2.3m)	Swing clearance, rear of upperstructure
F 10'10" (3.3m)	10'6" (3.2m)	Top of cab to ground line
G 51" (1.3m)	47" (1.2m)	Clearance, upperstructure to ground line
H 48" (1.2m)	44" (1.1m)	Top of wheel mounted undercarriage frame to ground line
L 20'3" (6.2m)	20'3" (6.2m)	Overall length of undercarriage
N 10" (250mm)	10" (250mm)	Ground clearance (per SAE J1234)
P 30" (760mm)	30" (760mm)	Center of rear axle to axis of rotation
R 13'0" (4.0)	13'0" (4.0)	Wheel base
S 32" (810mm)	32" (810mm)	Center of rear axle to rear of frame (step)
V1 6'5" (2.0m)	6'5" (2.0m)	Tread, rear axles 4x4 (10:00 x 20 tires), 4x2 (Spoke Wheels)
V2 7'1" (2.2m)	6'10" (2.1m)	Tread, front axle 4x4 (15:00 x 22.5 tires), 4x2 (Spoke Wheels)
AA 27'5" (8.4m)	27'5" (8.4m)	Maximum radius at ground line (165° pivot)
AB 19'4" (5.9m)	19'8" (6.0m)	Maximum digging depth (165° pivot)
AC 17'6" (5.3m)	17'10" (5.4m)	Maximum depth for 8' level cut
AD 5'11" (1.8m)	5'11" (1.8m)	Maximum radius of 8' level cut at depth "AC"
AF 18" (460mm)	18" (460mm)	Maximum depth of vertical wall which can be excavated
AG 11'3" (3.4m)	11'4" (3.5m)	Minimum level cut radius with bucket flat on ground line
AH 6'11" (2.1m)	7'3" (2.2m)	Minimum radius at ground line
AK 6'2" (1.9m)	5'11" (1.8m)	Boom pivot to ground line
AL 15.3" (390mm)	15.3" (390mm)	Boom pivot to axis of rotation
AP 46" (1.2m)	46" (1.2m)	Bucket tooth radius
AQ 32° Up & 75° Down	32° Up & 75° Down	Boom pivot angle
AS 165°	165°	Bucket pivot angle

4 x 4	4 x 2	
AU 23'0" (7.0m)	23'0" (7.0m)	Maximum telescoping boom length (boom pivot to bucket pivot)
AV 12'0" (3.6m)	12'0" (3.6m)	Minimum telescoping boom length (boom pivot to bucket pivot)
AW 11'0" (3.3m)	11'0" (3.3m)	Telescoping boom travel
AX 110°	110°	Bucket tilt angle (both sides of center)
BA 28'1" (8.6m)	28'1" (8.6m)	Maximum radius of working equipment
BB 23'5" (7.1m)	23'1" (7.0m)	Minimum clearance of bucket teeth, with bucket pivot at maximum height
BC 21'7" (6.6m)	21'3" (6.5m)	Maximum bucket tooth height
BD 16'3" (5.0m)	15'11" (4.8m)	Minimum clearance of bucket teeth, with bucket pivot at maximum height
BE 10'11" (3.3m)	10'7" (3.2m)	Minimum clearance of fully curled bucket at maximum boom height
BF 10'6" (3.2m)	10'3" (3.1m)	Minimum clearance of bucket teeth at maximum boom height
BG 13'5" (4.1m)	13'2" (4.0m)	Maximum height of working equipment with bucket below ground line
BH 23'3" (7.1m)	23'3" (7.1m)	Radius of bucket teeth at maximum height
BJ 16'9" (5.1m)	16'9" (5.1m)	Minimum radius of bucket teeth at maximum bucket pivot height

Rated boom force:
21,940 lb (97.6kN)

Rated bucket breakout force:
17,990 lb (80kN)

Weight:
Approximate working weight, including 30" (762mm) bucket, fuel tank half full.
4x2: 39,486 lb (17,911 kg)
4x4: 41,176 lb (18,677 kg)

Specifications subject to change without notice.

Optional Equipment

Vandalism protection kit including window covers.

Intake air pre-cleaner.

Exhaust spark arrestor.

Strobe light.

Block heater.

Additional battery.

Tilt steering column.

Auxiliary Hydraulics - Additional hoses and piping for hydraulic powered attachments. [Maximum pressure 4800 psi (33,095 kPa) Maximum flow 30 GPM (114 L/min)]

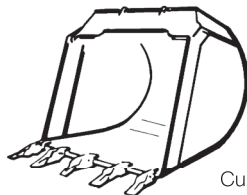

Part No.	Size	Cu. yd.	m ³
8045-6020	24" (610mm) Excavating bucket	3/8	.31
8045-6021	30" (762mm) Excavating bucket	1/2	.41
8045-6022	36" (914mm) Excavating bucket	5/8	.54
8045-6023	42" (1.07m) Excavating bucket	3/4	.64
8045-6024	48" (1.22m) Excavating bucket	1	.76



Part No.	Size	Cu. yd.	m ³
8065-6013	72" (1.83m) Dredging bucket	1 1/8	.87

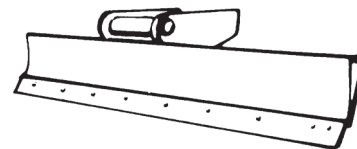

8065-6024 8' (2.4m) Grading blade

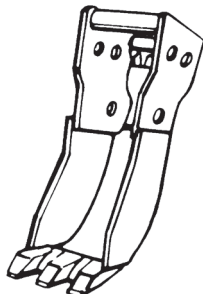

Part No.	Size	Cu. yd.	m ³
8065-6104	15" (381mm) Trenching bucket	1/5	.15
8065-6012	21" (533mm) Trenching bucket	1/4	.19

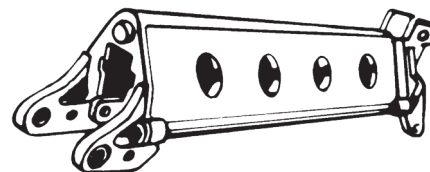

8065-5028 4' (1.2m) Boom extension
8065-5029 6' (1.8m) Boom extension
8065-5030 8' (2.4m) Boom extension

Attachments

Quick change and reversible buckets fabricated of steel plate, with high strength, low alloy cutting edges and wear strips. Standard attachments available for wide range of applications. Capacities shown are in heaped cu. yd.

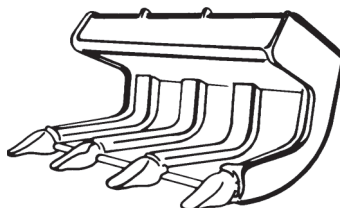

8065-6102	40" (1.02m) Pavement removal bucket
8065-6115	18" (457mm) Pavement removal bucket
8065-6116	24" (610mm) Pavement removal bucket
8065-6114	28" (711mm) Pavement removal bucket

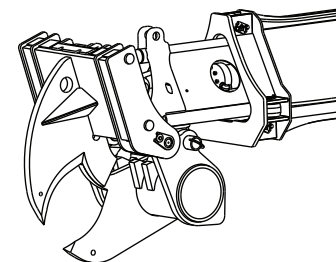

80455052 Tree Limb Shear Attachment

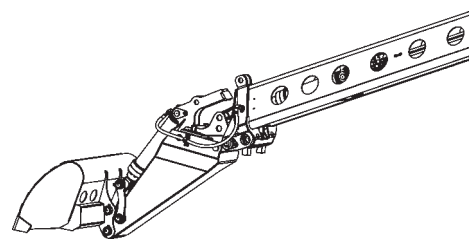

8045-5009 6' (1.8 m) Live Boom

It is Gradall Policy to continually improve its products. Therefore designs, materials and specifications are subject to change without notice and without incurring any liability on units already sold. Units shown may have optional equipment.

GRADALL®

406 Mill Ave. SW, New Philadelphia, Ohio 44663
Phone: 330-339-2211 Fax: 330-339-8468
www.gradall.com



Certified ISO 9001

Form No. 11005. Replaces Form No. 10905.
Printed in USA

6/10

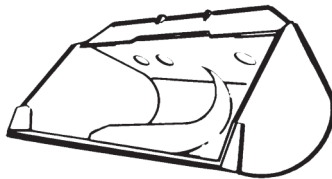

Part No.	Size	Cu. yd.	m ³
8065-6040	30" (.762m) Ditching bucket	3/8	.3
8065-6007	60" (1.52m) Ditching bucket	7/8	.73
8065-6006	66" (1.68m) Ditching bucket	1	.76
8065-6002	72" (1.83m) Ditching bucket	1 1/8	.87

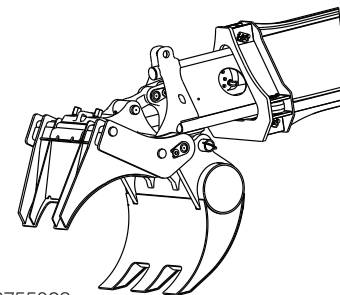

80755023 Fixed Thumb Grapple